

CFD ANALYSIS – UNI FLOW VORTEX TUBE

INTRODUCTION

Vortex Tube is a non-conventional air conditioning system that comprises no moving parts but could produce both hot and cold temperatures at its terminals. The design of this, mostly depends on the complex phenomenon of temperature separation that occurs by the inherited qualities of vorticity of fluid motion. Computational Simulation of the Fluid Flow was made to have an insight over the domain physics and various modifications to improve its COP.

With the aid of the CFD technology, the complex vortical flows of various fluids in vortex tube can be vividly captured and the design progress can be accelerated. Thus, CFD is an important tool for Turbo machinery industries as it will reduce the time consuming and expensive experimental procedures.

SCOPE OF THIS RESEARCH WORK

- ✦ To predict the occurrence of bifurcation point inside the tube.
- ✦ Get a higher temperature separation with various modifications of L/D ratios and inlet pressures.
- ✦ Improve the performance characteristic by modifying the working fluid inside the system.

REVERSE ENGINEERING PROCESS

The Uniflow Vortex Tube (UFVT) is scanned based on the reverse engineering in Coimbatore Industrial Infrastructure Association (CO-INDIA) Avarampalayam, Coimbatore. By using CAD software package Pro-E Wildfire 5.0, the drawing was generated.

CFD ANALYSIS

With a goal of increasing the temperature separation of the UFVT, CFD is utilized in a following systematic way.

✦ VALIDATION STUDY

CFD procedure has lot of variables such as grid count, turbulence model, and discretization scheme, so it is important for a CFD engineer to play between those variables without affecting the solution accuracy. A commercial Computational Fluid Dynamics (CFD) code, ANSYS Fluent V13.0 with a k-ε Standard turbulence model with Second Order Discretization Scheme was used to study the occurrence of bifurcation point and the temperature separation.

The numerical results are compared with the experimental data of the base model to arrive at the best computational procedure (BCP).

PERFORMANCE ENHANCEMENT STUDY

The Performance of the UFVT depends on temperature separation which is proportional to the increase in the distance of bifurcation point, that implicitly depends over the Length and the diameter of the travel tube, and other parameters like number of inlets, pressure of the fluid, working fluid etc., Here, inlet pressure, L/D ratio and working fluids are taken as the major variables of optimization.

UTILIZATION OF DOE METHODOLOGY

Taguchi method is a scientifically disciplined mechanism for evaluating and implementing improvements in products, processes, materials, equipment, and facilities. These improvements are aimed at improving the desired characteristics and simultaneously reducing the number of defects by studying the key variables controlling the process and optimizing the procedures or design to yield the best results.

INFLUENCE OF CFD TECHNIQUE IN THIS PROBLEM

This Uniflow Vortex tube highly depends on the complex configuration of sonic velocity occurrence of the vortices and other inlet parameters. The geometrical parameters like the ratio of length and diameter of the travel tube (L/D) plays a vital role in the distance of occurrence of the bifurcation point. The distance can be empirically calculated as $0.25L$.

*****Using CFD, the results for 3 different modifications of L/D for 3 working fluids was simulated within less time whereas experiments need lot of time and cost investment to test individual modification itself. No experiment will provide an INSIGHT views like the pressure contour, velocity vectors in different planes and positions as shown in Fig 2, Fig 3, Fig 4 and Fig 5.**

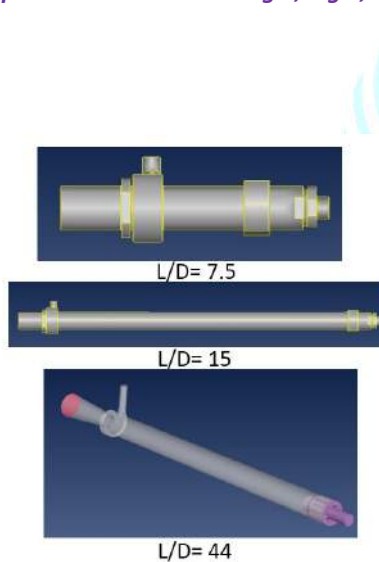

Fig 1.Modifications on L/D

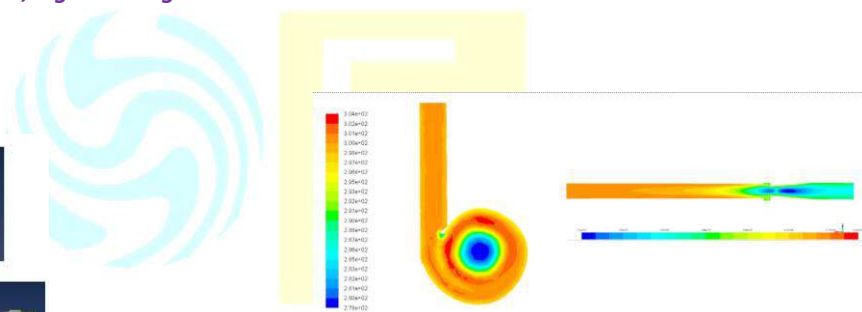

Fig 2.Temperature contour

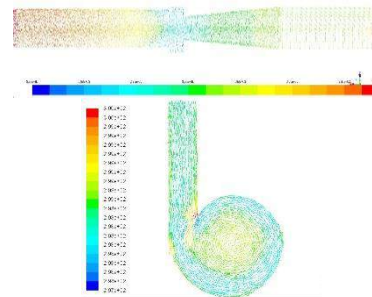

Fig 3.Pressure vectors

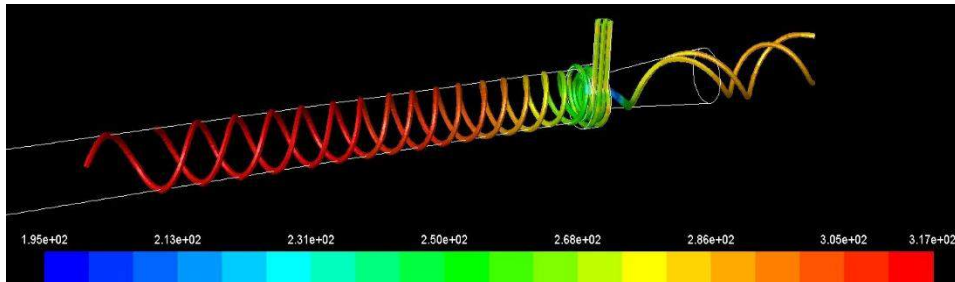

Fig 4.Path lines of Temperature

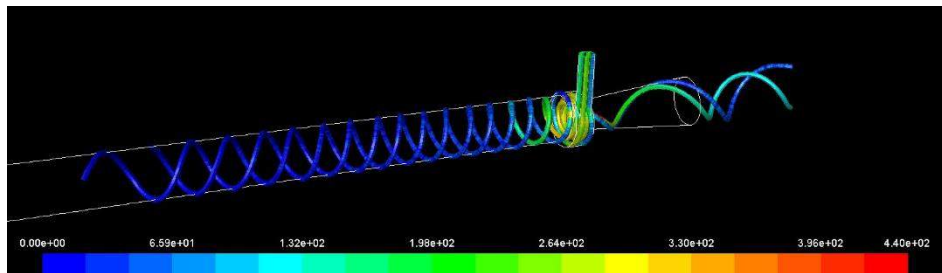

Fig 5.Path lines of Velocity

******* Above Figures shows the colour path lines of vortical flow of fluid at 6 bar pressure. And it is impossible to get this much detailed view of velocity and temperature profiles when we go for experiments so this is the place where one can see the merits of CFD techniques.

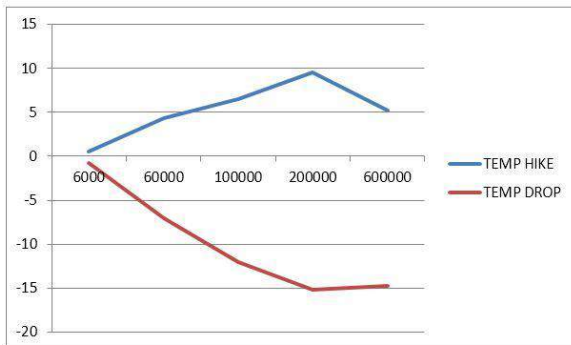

Fig: Pressure vs Temperature difference

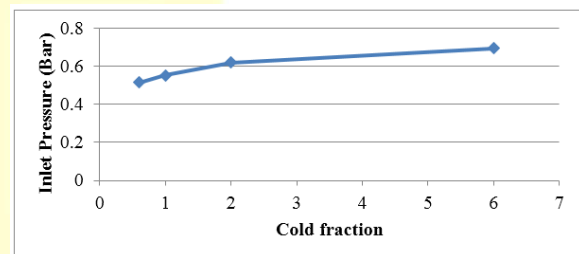

Fig: Cold mass fraction vs Inlet Pressure

CONCLUSION

- ✓ A validation study achieving the best practice of CFD and followed for further analysis.
- ✓ An optimization study is tried out using Taguchi method by varying three major parameters such as L/D ratio, inlet pressure and the working fluid of the system. An optimum configuration is achieved after comparing the results.
- ✓ Among 3x3 different variations, the optimum L/D and working fluid is achieved by comparing the simulation results.